

## Marine Diesel Engine

# V158TI

- Compact Design
- Excellent Performance
- Low Fuel Consumption
- Easy Maintenance

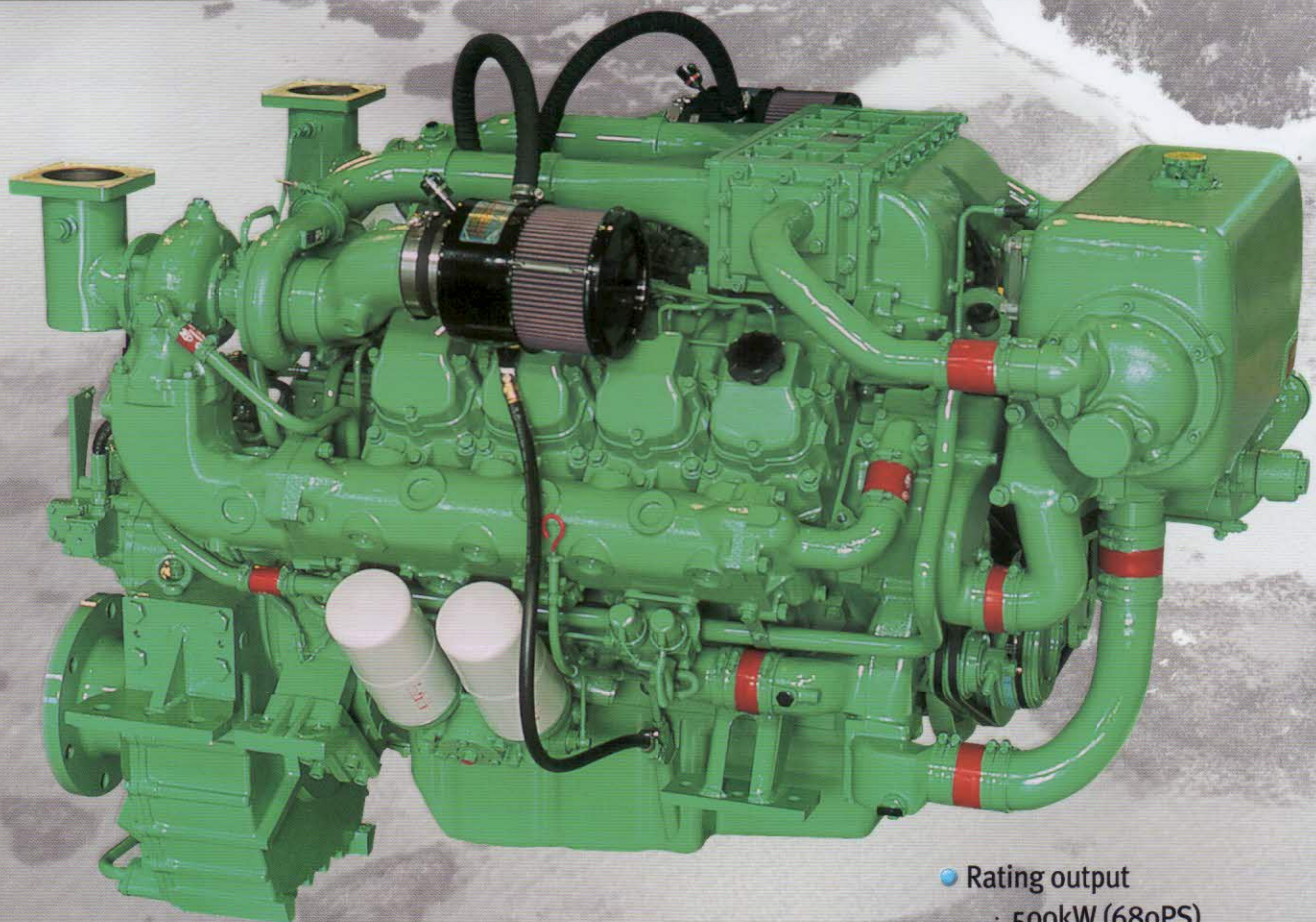

- Rating output  
· 500kW (680PS)
- Displacement  
· 14,618cc
- Dimension (L × W × H)  
· 1,337 × 1,223 × 1,074mm  
· Without Reduction Gear



## Main Specification

Model	Units	V158TI (D2848LB)		
		V158TIH	V158TIM	V158TIL
Engine type		4cycle, V type, direct-injection, water cooled with wet turbo charger & inter-cooler		
Rating output	PS(kW) / rpm	480(353)/1,800	540(397)/2,100	680(500)/2,300
Displacement	cc	14,618		
Cylinder number - bore × stroke	mm	8 -128×142		
Low idling rpm	rpm	725 ± 25		
No load max. rpm	rpm	below 2,070	below 2,415	below 2,645
Compression ratio		15 : 1		14.6 : 1
Firing order		1 - 5 - 7 - 2 - 6 - 3 - 4 - 8		
Governor type of injection pump		Mechanical variable speed (R.Q.V)		
Fuel consumption(only Ref.)	g / PS.h	147	154	159
	Lit / h	85	100	130
Starting system		Electric Starting by starter motor		
Starter motor capacity	V - kW	24 - 6.6		
Alternator capacity	V - A	24 - 50		
Battery	V - Ah	24 - 200		
Cooling system		Indirect sea water cooling with heat exchanger		
Cooling water capacity	Max. / Min.	lit	89 / 78	
Fresh water pump type		Centrifugal type, driven by belt		
Sea water pump type		Bronze impeller type driven by belt		
Lubricating oil(Engine)	Pan capacity	lit	Max : 31, Min : 25 (Engine total : 35)	
Direction of revolution	Crankshaft	Counter clockwise viewed from stern side		
Engine Size(L×W×H)	Without M/G	mm	1,337×1,223×1,074	
Engine dry weight	Without M/G	kg	1,350	1,435

※ H : Heavy Duty, M : Medium Duty, L : Light Duty

## Engine Dimension

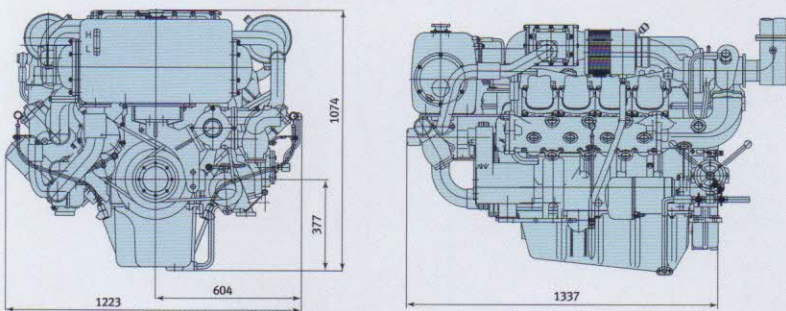

## Performance Curve

- Heavy duty : 353kW(480PS)@1,800rpm
- Medium duty : 397kW(540PS)@2,100rpm
- Light duty : 500kW(680PS)@2,300rpm

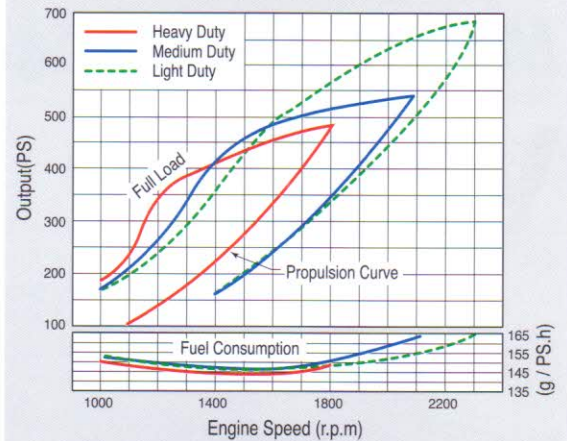

### Marine rating to ISO 3046

#### (1) Heavy Duty

Operation hours are unlimited per year, at average load is up to 90 %, at full load is up to 80 %  
 Typical gearbox ratio: 2.5 ~ 6  
 (Fishing trawler, Tug boat, Pushing vessel, Cargo boat, Freighter, Ferry)

#### (2) Medium Duty

Operation hours are up to 3,000 per year, at average load is up to 70 %  
 At full load is (up to 30 % / 4hrs per 12 hour operation period)  
 Typical gearbox ratio: 2 ~ 3.5  
 (Fishing boat, Pilot boat, Escort boat, Passenger boat, Ferry, Cruising vessel)

#### (3) Light Duty

Operation hours are up to 1,000 per year, at average load is up to 50 %  
 At full load is (up to 20 % / 2hrs per 12 hour operation period)  
 Typical gearbox ratio: 1 ~ 2.5  
 (Light weight fishing boat, Yacht, Coastguard boat, Fast boat, Fire pump, Navy)

(Dec.2006)



**Doosan Infracore  
Engines & Materials**

**Seoul Office :** Overseas Marketing & Sales  
 Engines & Materials BG  
 Doosan Infracore Co., Ltd.  
 23rd Floor, Doosan Tower, 18-12, Euljiro 6-ga,  
 Jung-gu, Seoul, Korea.  
 Tel : +82-2-3398-8530~8546  
 Fax : +82-2-3398-8509  
**Web site :** <http://engine.doosaninfracore.co.kr>

AUTHORIZED DEALER

\* Specifications are subject to change without prior notice.